

**FULL SERVICE SEAL KIT FOR
HIGH PRESSURE PNEUMATIC PUMP
MODEL PGPH**

Bag #	Use
1	For Low Pressure piston. See pages 2, 3 and 4.
2	For High Pressure piston. See pages 2, 3 and 4.
3	For seals between High and Low Pressure section. See pages 2, 3 and 4.
4	For Low Pressure check valve. See pages 2, 3 and 4.
5	For high Pressure check valve. See pages 2, 3 and 4.
6	For Pressure Selector. See pages 2, 3 and 5.
7	For Fine Adjust piston. See pages 2, 3 and 5.
8	For Shut-off valve's shaft. See pages 2, 3 and 5.
9	For sealing connections between sections inside PGPH.

Dear user,

We have made every effort to ensure the accuracy of the contents of this manual. Should any errors be detected, we would greatly appreciate to receive suggestions to improve the quality of the contents of this manual.

For more detailed technical data about the Instruction manual for Beamex® PGPH High Pressure Pneumatic Pump, please contact the manufacturer.

© Copyright 2015

BEAMEX OY AB
Ristisuonraitti 10
FIN-68600 Pietarsaari
FINLAND

Tel	+358 - 10 - 5505000
Fax	+358 - 10 - 5505404
E-mail:	sales@beamex.com service@beamex.com
Internet:	http://www.beamex.com

CONTENTS OF SERVICE KIT

The contents of PGPH Service Kit are listed on the front page of this leaflet. Also, a general overview of PGPH and where the seals are located is found on page 2 and onwards

Disassembling PGPH

Tools needed: 4 mm hex and a Torx 10 screwdrivers, 19 mm, 23 mm and 27 mm spanners plus pointed pliers.

This procedure refers to the general overview picture on pages 2 and 3. Further information is on page 5.

1. Start by pulling out the cover with the Beamex's product label seen to the left in the overview picture.
2. Open the four hex screws located behind the cover and remove the Volume Section. Watch out for seals that may drop on the table.
Now you have access to two of the 4 x 2 O-rings found in **High pressure section**.
You also have access to the high pressure check valve, located at the end of the high pressure cylinder, its 2.5 x 1.5 O-ring and spring.
3. To remove the Pressure Connection Part, unscrew the four hex screws at the bottom of the pump.
Now you have access to the third of the 4 x 2 O-rings found in **High pressure section**.
4. Open four more hex screws connecting the **High pressure section** to the **Low pressure section**. Gently pull out the **High pressure section's** block.
Now you have access to the low pressure check valve, located in the Low pressure section, its 2.5 x 1.5 O-ring and spring.
5. Gently pull out the high pressure cylinder.
Now you have access to the seals related to the high pressure piston. Detail picture available on page 4.
6. The pump shaft can be split from behind the high pressure piston. Do it to have access to the low pressure piston.
7. Remove the lock ring and use the pointed pliers to pull out the block separating the high pressure pump from the low pressure pump.
By opening the block you have access to the 8 x 2 O-ring and seal.
8. Remove the shield using the Torx 10 screwdriver.
By gently pulling out the low pressure section you have access to the low pressure piston and its 34 x 3 O-ring and seal. Detail picture available on page 4.
9. To replace the guide ring, open the four screws holding the guide ring in place. Then you can remove the low pressure piston from the shaft.

Notes.

PGPH should be disassembled by skilled people and in an environment where all parts can be safely put aside until the pump is reassembled.

Several of the seals may fall out during the disassembling procedure

PGPH Parts

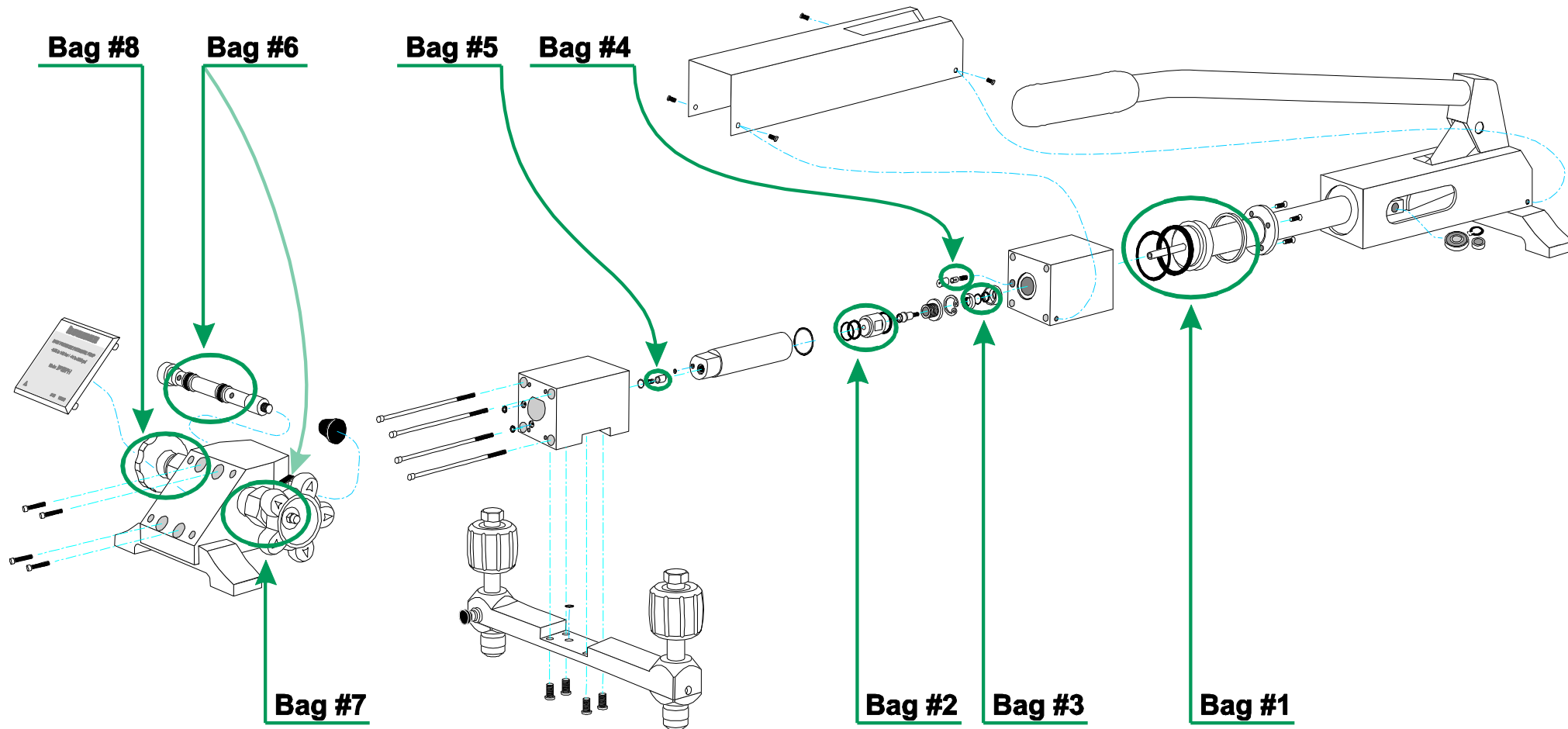

Bag #	Use
1	For Low Pressure piston. See also page 4.
2	For High Pressure piston. See also page 4.
3	For seals between High and Low Pressure section. See also pg 4.
4	For Low Pressure check valve. See also page 4.
5	For High Pressure check valve. See also page 4.

Bag #	Use
6	For Pressure Selector. See also page 5.
7	For Fine Adjust piston. See also page 5
8	For Shut-off valve's shaft. See also page 5
9	For sealing connections between sections inside PGPH.

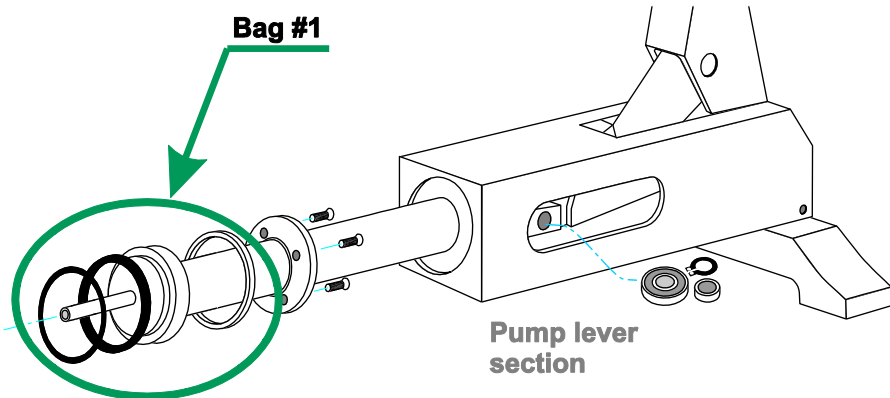

Detail of low pressure piston and pump lever section.

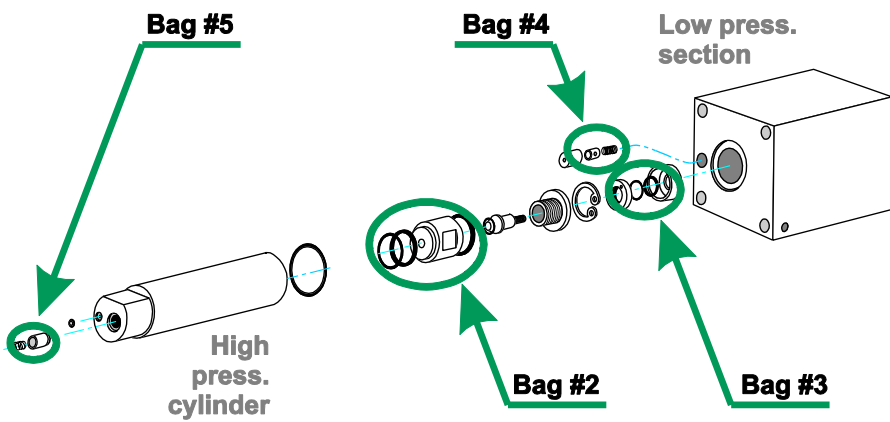

Detail of high pressure cylinder and piston, block separating the high pressure pump from the low pressure pump and the low pressure section.

Disassembling the Pressure Selector

The pressure selector is located in the **Volume section**. See adjacent picture. To disassemble it, rotate the selector knob counterclockwise until it is loose. Then pull out the shaft from the opposite side of volume section.

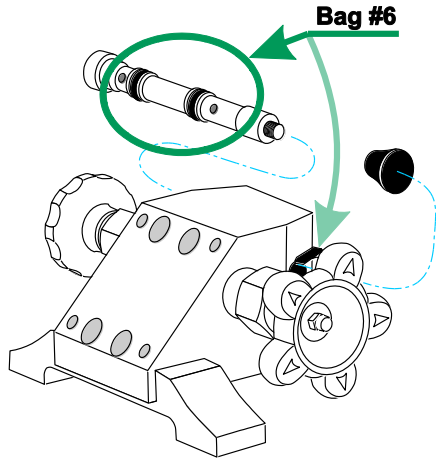

Volume section

Detail of pressure selector.

Disassembling the Shut-off Valve

See picture below. First off, fully open the shut-off valve. This gives ample room to open the nut holding the valve in place. Use a 24 mm spanner to reveal the 19 mm nut and open it too. Gently pull out the shaft. Bag 8 contains the replaceable parts for the shaft.

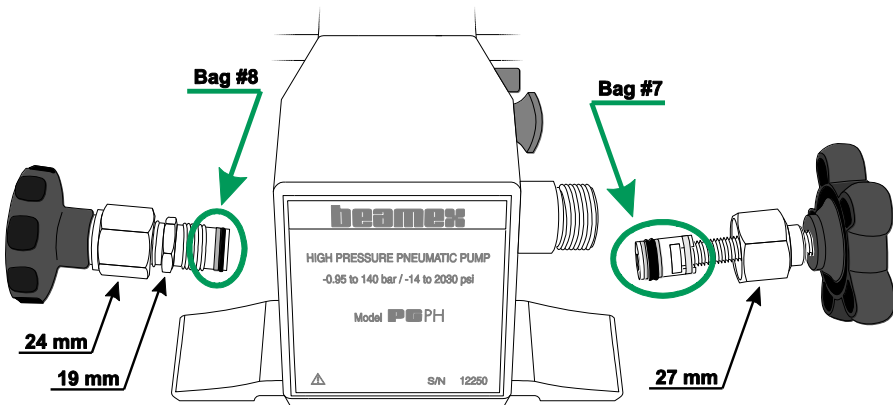

Details of Shut-off valve and Fine Adjustment piston.

Disassembling the Fine Adjust Piston

See picture below. Use a 27 mm spanner to open the nut and gently pull out the piston. Bag 7 contains the replaceable parts for the piston.

beamex

BEAMEX OY AB Ristisuonraitti 10 FIN-68600 PIETARSAARI FINLAND Phone +358 - 10 5505000 Fax +358 - 10 5505404 E-mail sales@beamex.com service@beamex.com Internet http://www.beamex.com	Beamex Inc 2152 NW Parkway Suite A Marietta, GA 30067 U.S.A. Phone 800 888-9892, +1-770-951-1927 Fax +1-770-951-1928 E-mail beamex.inc@beamex.com
Beamex Limited Newtown Grange Farm Business Park Desford Road NEWTOWN UNTHANK Leicestershire LE9 9FL United Kingdom Phone 01455 821 920 Fax 01455 821 923 E-mail beamex.ltd@beamex.com	Representative: